

ALEXTR-2002 - CARGO FINGER RAIL

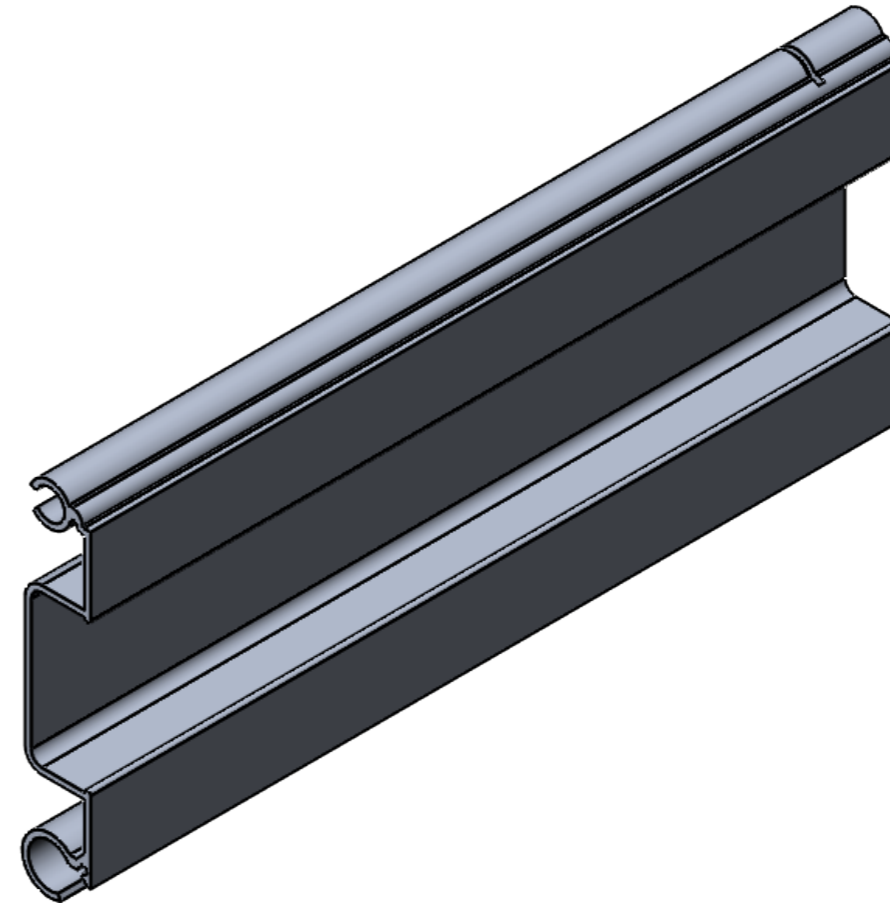

GENERAL TOLERANCES

Linear Measurements:
Unless Otherwise Stated
+/- .002
Angular Measurements:
Unless Otherwise Stated
+/- 0.5 deg.

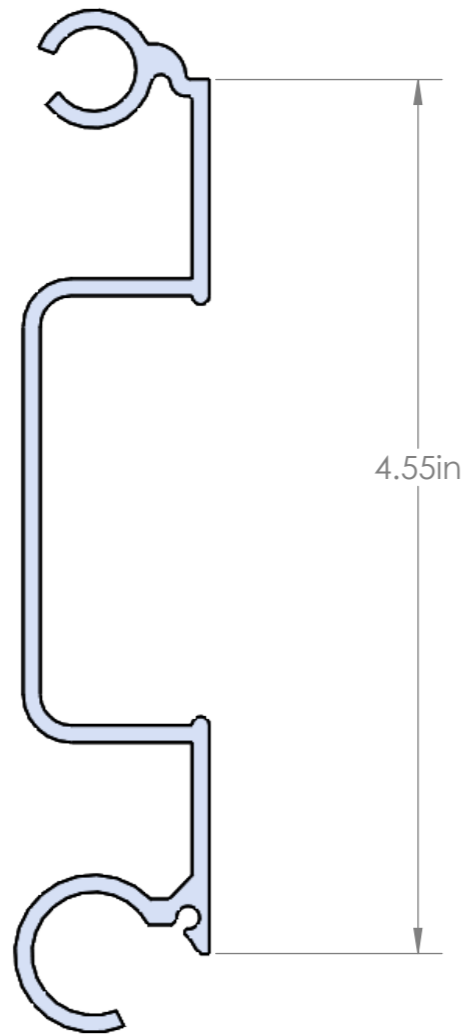

DIAMOND ROLL-UP DOOR, INC.
295 COMMERCE WAY
UPPER SANDUSKY, OH 43351
PHONE: 419-294-3373 FAX: 419-294-3329

CONFIDENTIAL NOTE: This drawing and its specifications and engineering information disclosed hereon are the property of DIAMOND ROLL-UP DOOR, INC/ DOVER ROLLER SHUTTERS and are not to be disseminated or reproduced without express written consent. The drawing is loaned in confidence and then only for consideration of the material disclosed hereon. In accepting loan of this drawing, the recipient agrees to keep it and the material disclosed hereon in confidence and not to use nor permit their use in any way detrimental to DIAMOND ROLL-UP DOOR, INC / DOVER ROLLER SHUTTERS.

DESCRIPTION: CARGO FINGER RAIL		
DRAWN BY: B. COURTNEY	DWG NO.	
PART #: ALEXTR-2002	SCALE:1:5	SHEET 1 OF 1