

IMPORTANT PLEASE READ

1. INTER LOCK & SLIDE PANELS TOGETHER
2. INSERT PANEL WASHER INTO PRE-CUT SLOT THRU BOTH PANELS
3. SLIDE THE ROLLER STEM THRU THE WASHER IN THE CHANNEL.

THIS WILL KEEP THE PANELS ALIGNED AND STOP THEM FROM WONDERING FROM SIDE TO SIDE.

*****OMITTING THIS STEP WILL CAUSE DAMAGE TO YOUR DOOR.*****

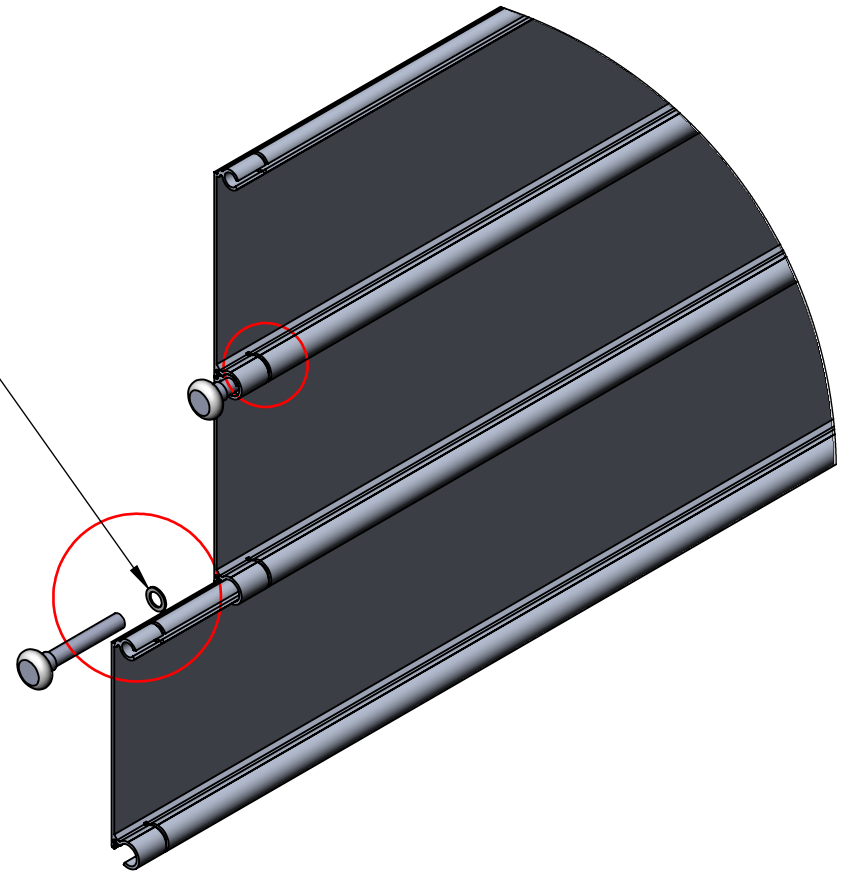

CONFIDENTIAL NOTE: This drawing and its specifications and engineering information disclosed hereon are the property of DIAMOND ROLL-UP DOOR, INC/ DOVER ROLLER SHUTTERS and are not to be disseminated or reproduced without express written consent. The drawing is loaned in confidence and then only for consideration of the material disclosed hereon. In accepting loan of this drawing, the recipient agrees to keep it and the material disclosed hereon in confidence and not to use nor permit their use in any way detrimental to DIAMOND ROLL-UP DOOR, INC / DOVER ROLLER SHUTTERS.

DIAMOND
DIAMOND ROLL-UP DOOR, INC.

DOVER ROLLER SHUTTERS
295 COMMERCE WAY
UPPER SANDUSKY, OH 43351
PHONE: 419-294-3373 FAX 419-294-3329